

**rotork**<sup>®</sup>  
Controls

**SM-1700 Series**  
Instruction Manual

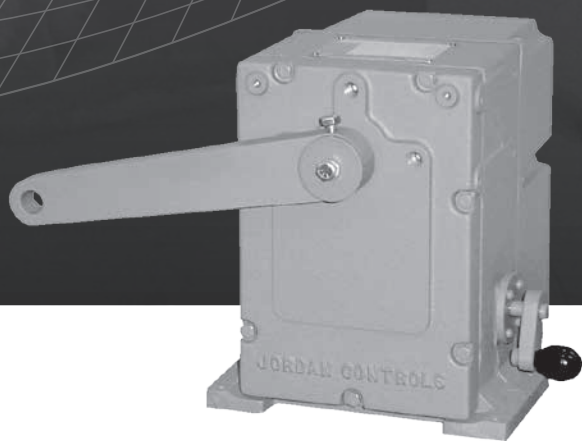

**Electric Actuators and Control Systems**

**Keeping the World Flowing**

# Contents

Section	Page
General Information	3-4
Introduction	3
Cautions	3
Receiving/Inspection	3
Storage	3
Equipment Return	3
Identification Label	4
Abbreviations Used in This Manual	4
General Actuator Description	4
Basic Models	4
Specifications	5-6
Actuator	5
Options	6
Installation	6-7
Typical Wiring Diagrams	8-9
Start Up	10-12
Troubleshooting	13-14
Parts Identification	15-17
Parts List	18-19
Maintenance	20-21
Linkage Options	22
Major Dimensions	23

**DUE TO WIDE VARIATIONS IN THE TERMINAL NUMBERING OF ACTUATOR PRODUCTS, ACTUAL WIRING OF THIS DEVICE SHOULD FOLLOW THE PRINT SUPPLIED WITH THE UNIT.**

IM-0468

## General Information

### INTRODUCTION

Rotork Controls, designs, manufactures, and tests its products to meet national and international standards. For these products to operate within their normal specifications, they must be properly installed and maintained. The following instructions must be followed and integrated with your safety program when installing, using, and maintaining Rotork Controls products:

- Read and save all instructions prior to installing, operating, and servicing this product.
- If any of the instructions are not understood, contact your Rotork Controls representative for clarification.
- Follow all warnings, cautions, and instructions marked on, and supplied with, the product.
- Inform and educate personnel in the proper installation, operation, and maintenance of the product.
- Install equipment as specified in Rotork Controls installation instructions and per applicable local and national codes. Connect all products to the proper electrical sources.
- To ensure proper performance, use qualified personnel to install, operate, update, tune, and maintain the product.
- When replacement parts are required, ensure that the qualified service technician uses replacement parts specified by Rotork Controls. Substitutions may result in fire, electrical shock, other hazards, or improper equipment operation.
- Keep all actuator protective covers in place (except when installing, or when maintenance is being performed by qualified personnel), to prevent electrical shock, personal injury, or damage to the actuator.

### WARNING

Before installing the actuator, make sure that it is suitable for the intended application. If you are unsure of the suitability of this equipment for your installation, consult Rotork Controls prior to proceeding.

### WARNING - SHOCK HAZARD

**Installation and servicing must be performed only by qualified personnel.**

### WARNING - ELECTROSTATIC DISCHARGE

**This electronic control is static-sensitive. To protect the internal components from damage caused by static discharge, never touch the printed circuit cards without being statically protected.**

### RECEIVING INSPECTION

Carefully inspect for shipping damage. Damage to the shipping carton is usually a good indication that it has received rough handling. Report all damage immediately to the freight carrier and Rotork Controls. Verify that the items on the packing list or bill of lading agree with your own.

### STORAGE

If the actuator will not be installed immediately, it should be stored indoors in a clean, dry area where the ambient temperature is not less than -20° F. The actuator should be stored in a non-corrosive environment. The actuator is not sealed to NEMA 4 until the conduit entries are properly connected.

### EQUIPMENT RETURN

**A Returned Goods authorization (RG) number is required to return any equipment for repair.** This must be obtained from Rotork Controls.

(Telephone: 414/461-9200) The equipment must be shipped, freight prepaid, to the following address after the RG number is issued:

Rotork Controls  
5607 West Douglas Avenue  
Milwaukee, Wisconsin 53218  
Attn: Service Department

To facilitate quick return and handling of your equipment, include:

RG Number on outside of box  
Your Company Name, Contact Person, Phone/Fax #  
Address  
Repair Purchase Order Number  
Brief description of the problem

# General Information

## IDENTIFICATION LABEL

An identification label is attached to each actuator cover. The serial number is also stamped on the aluminum housing, directly above the conduit entry. When ordering parts, requesting information or service assistance, please provide all of the label information.

EXAMPLE:

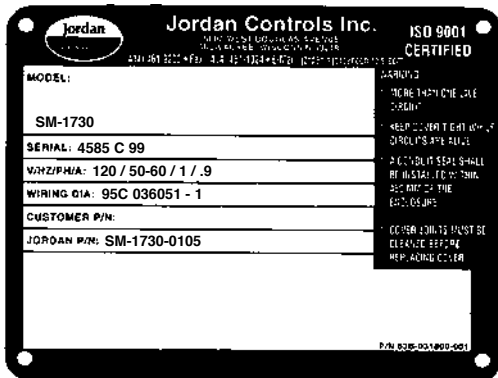

MODEL NUMBER: SM-1730 Series

SERIAL NUMBER: 4585 C 99  
 Sequential Number — Year Built  
 Month Built

## GENERAL DESCRIPTION, ACTUATOR

The SM-1700 series actuators are electrically operated, self-contained, bi-directional, low speed, high torque devices. They are designed for up to 360° rotation with bi-directional torque overload protection and have a non-clutchable manual override handcrank. The drive motor may be single or three phase ac or dc. Up to six independently adjustable position limit switches, linear potentiometer or characterized LVDT and 4 to 20 mA feedback are available as options. Other options include thermostatically controlled anti-condensation heater, local control switches, integral or remote servo amplifiers and linkage components.

The SM-1700 series includes 120/240 Vac single phase models, 240/380/480 Vac three phase models and 24 Vdc models. These actuators are controlled by “switched” power inputs or by a remotely installed servo amplifier.

The SM-1700/AD-8130 series feature an integral servo amplifier. These models require 120 or 240 Vac (depending on model) unswitched, single phase line voltage input and a dc analog command signal for a complete, closed-loop positioning system in a compact enclosure.

## ABBREVIATIONS USED IN THIS MANUAL

A	.....	Ampere
AC	.....	Alternating Current
° C	.....	Degrees Celsius
CW	.....	Clockwise
CCW	.....	Counterclockwise
DC	.....	Direct Current
° F	.....	Degrees Fahrenheit
G	.....	Earth Ground
Hz	.....	Hertz
in. lbs.	.....	Inch Pounds
kg	.....	Kilogram
L	.....	Line (power supply)
lbs.	.....	Pounds Force
LVDT	.....	Linear Variable Differential Transformer
mA	.....	Milliamp
mfd	.....	Microfarad
mm	.....	Millimeters
N	.....	Newton (force)
NEMA	.....	National Electrical Manufacturing Association
Nm	.....	Newton Meter
NPT	.....	National Pipe Thread
PH	.....	Phase
PL	.....	Position Limit Switch
RPM	.....	Revolutions per Minute
SEC	.....	Second
TL	.....	Torque Limit Switch
V	.....	Volts
VA	.....	Volt Amps
Vac	.....	Volts ac
Vdc	.....	Volts dc
VR	.....	Variable Resistance
W	.....	Watt

## BASIC MODELS

**SM-1720, SM-1730, SM-1750 and SM-1790** are all single phase ac, three wire, plug reversible models. They are compatible with Rotork Controls remotely located AD-8230/EC-10836 servo amplifier, MT-6220 manual remote control with position readout, or any bi-directional contact type control.

These actuators may also be equipped with an integral model AD-8130 servo amplifier that features loss of signal detection for current command signal inputs and can be calibrated to allow the actuator to lock-in-place or drive to a preset position should the command signal drop below 3.8mA. Also included is a dynamic brake circuit to increase positioning accuracy and a loop-powered, 4 to 20mA position transmitter.

The **SM-1715** is a three phase ac, reversible model compatible with Rotork Controls remotely located AD-8900 series servo amplifier or any bi-directional contact type control.

The **SM-1740** is a dc proportional control model and is compatible with Rotork Controls remotely located model AD-7530 servo amplifier or other compatible control device.

# SM-1700 Series Rotary Electric Actuator

## GENERAL SPECIFICATIONS

### Speed/Torque:

**Model	*Time/Torque sec./in. lbs. (Nm)
SM-1715	12/1200 (136), 24/1200 (136), 48/1200 (136)
SM-1720 SM-1790	60/1800 (203), 31/1800 (203) 60/2400 (271)
SM-1730	12/1200 (136), 24/1200 (136), 48/1200 (136)
SM-1740	16/1000 (113), 31/1000 (113), 40/1000 (113)
SM-1750	12/1200 (136), 24/1200 (136), 48/1200 (136)

\*Multiply these shift times by 1.2 for 50 Hz operation of AC models. All travel times are for 90° movement of output shaft.

\*\*NOTE: Models SM-1710 and SM-1770 are no longer being offered. References to them are retained in this manual in order to provide service to the field. They are replaced by SM-1730 and SM-1750 respectively.

**Rotation:** Up to 90°

**Duty Cycle:** AC: 2,000 1% position changes/hour.  
DC: 4,000 1% position changes/hour.

**Temperature:** -40°F to 150°F (-40°C to 65°C)

**Environment Ratings:** NEMA Type 4 (IP65), Dust ignition proof, Class II, Division 1, Groups E, F & G

**Weight:** Approximately 40 lbs. (18.1 kg)

**Enclosure Materials:** Cast aluminum alloy

**Non-Rotating When Motor Runs**

**Handcrank Gear Ratio:** 1003:1

**Lubrication Type:** Permanently lubricated

**Gearing:** Spur gearing

**Hold on Loss of Power:** Motor drag brake

**Mounting:** Any position

**Torque Limiting:** Bi-Directional, disables motor when torque rating is exceeded.

**Output Shaft:** One inch (25.4mm) diameter with 0.25 inch square (6.35 mm) keyway, or one inch (25.4mm) diameter with 20 tooth spline.

## ELECTRICAL SPECIFICATIONS

Model	Input Power Volts/PH/Hz	Current (Amps)	
		Run	Stall
SM-1715*	240/3/50-60	0.4	1.3
	380/3/50	0.3	0.9
	480/3/50-60	0.2	0.65
SM-1720	120/1/50-60	0.9	1.2
SM-1730	120/1/50-60	0.9	1.2
SM-1740	24 Vdc	1.7	1.9
SM-1750 SM-1790	240/1/50-60	0.45	0.5

\*Input power specified at time of order and not field-changeable.

**Field Wiring:** To barrier type terminal blocks.

## MODELS WITH OPTIONAL AMPLIFIER

**Positioning Accuracy:** ± 0.25% of span

**Repeatability:** 0.1% of span

**Hysteresis:** 0.2% of span

**Linearity:** ± .8% of span

**Deadband:** 0.25% of span

**Integral Thermal Protection/Single Phase AC Motor:** 130°C

**End-of-Travel Position Limit Switches:** 20 amp, 250 Vac

# SM-1700 Series Rotary Electric Actuator

## OPTION SPECIFICATIONS

**Servo Amplifier:** Integral model AD-8130 for all single phase AC powered actuators or remote model AD-7530 for SM-1740 DC powered actuators or remote model AD-8900 for SM-1715 three phase actuators. Also model AD-8230/EC-10B36 for remote mounted single phase AC powered actuators.

Input Type	Input Impedance	
	AD-8130 AD-8230 AD-8900	AD-7530
4 to 20mA	200 ohms	510 ohms
0 to 5 Vdc	100,000 ohms	60,000 ohms
0 to 10 Vdc		

AD-8130 and AD-8230 series amplifiers include a field-adjustable command signal monitor that can be set for lock-in-place, or drive to a pre-set position if the current command signal is lost. They also have a dynamic brake circuit which helps increase positioning accuracy of the loop by minimizing motor coast. These amplifiers are also equipped with a 4-20mA isolated two wire, loop-powered transmitter.

**Anti-Condensation Heater:** 120 or 240 Vac, 30 Watt with thermostat set for 110°F (43.3°C).

**Local Auto/Manual INC/OFF/DEC Toggle Switches**

**Output Shaft:** 20 tooth splined shaft for use with splined drive arm.

**20 Tooth Splined Drive Arm:** Reversible for 1/2 tooth positioning.

**Adapter/Clevis Kit:** Includes two clevises, two adjustment rods with lock nuts, two pipe adapters, two pins for clevises.

**Auxiliary Position Limit Switches:** (two or four): 20 amps, 250 Vac maximum.

**Transmitter Position Feedback:** 4 to 20mA, isolated two wire loop-powered type.

**Local Position Indicator:** Reversible indicator.

**Contactless LVDT Position Feedback:** - Linear, square, square root and field contourable cams supplied.

**Potentiometer:** 1000 ohm, 2 watts, 36 Vdc max.

## Installation

### MOUNTING

The outline and mounting dimensions for a standard unit are shown on the last page of this manual. The rear cover opposite the output shaft must have clearance so it can be removed for adjustments and interconnect wiring.

When the actuator is directly coupled to a drive shaft, a Rotork Controls type coupling is recommended. The output shaft is also available with a splined output for standard drive arms and linkage components to the driven load.

The unit may be mounted on the standard foot mount, the face mount around the output shaft, or on two sets of side holes for a bracket mount. Mounting may be in any position convenient to the driven load. When mounting the unit, be sure that no excessive axial or side loading is applied to the output shaft.

The limit switches and position feedback are gear connected to the actuator output shaft. Positively secure the output shaft to the driven load shaft to prevent slippage, which would cause misalignment or damage.

The manual handcrank is engaged for operation at all times. When the manual override is required, the crank

should be turned in the appropriate direction for output shaft movement. If during manual operation electric power is applied to the actuator, this power cannot drive back through the manual handcrank and harm the operator. Power must be removed or motor position overrides manual position.

Torque of approximately seven inch pounds on the handcrank will provide up to 2,400 inch pounds at the output shaft. It takes approximately three full turns of the handcrank to move the actuator output shaft one degree. When the torque rating of the unit is reached, depending upon the direction of cranking, the handcrank will move in or out axially, an indication that full torque is being delivered to the load.

The motor, limit switch, and feedback area of the actuator depends upon the cover to maintain the NEMA Type 4 rating. This cover should be removed only when work is being done internally, and should be reinstalled immediately upon completion.

This unit contains no internal mechanical stops. If it runs outside of the initial factory alignment of the limit switches, a realignment of switches and feedback may be required. However, no internal damage will have occurred.



# Installation

## INSTALLATION WIRING

Typical wiring diagrams are shown on pages 7-8. **Actual wiring should follow the print supplied with the actuator.**

The wiring diagram shows the fundamental connections for the standard three-wire reversible single-phase motor, and the standard permanent magnet dc motor. These units show an arrangement with torque switches, four limit switches, two feedback potentiometers, and a heater. To meet special requirements, certain items shown may not be supplied. **In all instances the wiring diagram appropriate to the equipment will be supplied with each unit.**

A barrier type terminal strip is located under the rear cover opposite the output shaft. Two conduit entries are located in the side of the unit to accommodate standard 1 inch N.P.T. and inch N.P.T. fittings.

**CAUTION: On standard single-phase wiring, the position limit switches and the torque switches are wired directly in the motor circuit and protect it at the extremes of travel or at torque cutout. Three phase AC or DC units must have these torque and position limit switches wired into the controlling device to cause end of travel or torque shutdown. Care must be taken in wiring these to the controlling device so that the appropriate direction of control is turned off when that direction's limit switch is actuated. If care is not taken in phasing the equipment, damage may occur to the actuator or driven load. Also, inductive devices, such as lights and solenoids, must not be paralleled across motor terminals 1 and 2 or 1 and 3 as this will upset the motor capacitor phase shift and motor torque will be lost.**

- All wiring should be done in accordance with prevailing codes by qualified personnel.
- Fusing must be installed in line power, and should be of the slow blow type.
- Wiring should be routed to the actuator through the two conduit openings. Generally, one conduit will contain input power and earth ground wires. The other conduit would then contain low level input and output signal wiring. It is required that all low level signal wiring be a shielded type with the shield grounded at source common.
- After installation, it is required that all conduits be sealed to prevent water damage and to maintain NEMA 4 enclosure and applicable dust ignition ratings.

## ROTORK CONTROLS SUPPLIED (OPTIONAL) COUPLING (Field Installed)

Rotork Controls has designed a three piece "wedge-lock" coupling which can be adjusted to align the driven device to the actuator output shaft with no concern as to keyway alignment of the shaft with the drive device in relation to the spline on the actuator output shaft.

### ADJUSTMENT

1. Slide coupling (5) onto driven shaft.
2. Slide coupling cone (1) and cup (2) onto actuator shaft.

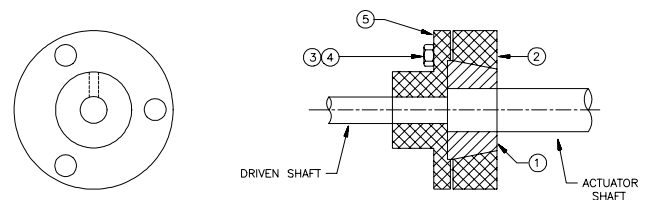

3. Mount actuator with the two shafts in line and the shaft ends about inch (3 mm) apart.
4. Turn the shaft of the driven device to the close position.
5. Run the actuator to the close limit switch.
6. Lock coupling (5) to the driven shaft by pinning or other suitable method.
7. Slide cone (1) to fit flat in recess of coupling (5).
8. Install three bolts and lockwasher (3) and (4) and tighten. (20-30 ft. lbs.)
9. Operate the actuator in the open direction and back to the close direction until the close limit switch stops the actuator.
10. If the driven shaft does not move to the exact close position you want, loosen the three bolts and turn the driven shaft. Tighten the bolts. (20-30 ft. lbs.)

**NOTE: Keep the coupling parts clean while assembling.**

See page 21 of this manual for Rotork supplied linkage components information.

# Typical Wiring Diagrams

## ACTUATOR WITHOUT A BUILT-IN AMPLIFIER

**SM-1720 & SM-1730 (120 Vac)**  
**SM-1750 & SM-1790 (240 Vac)**

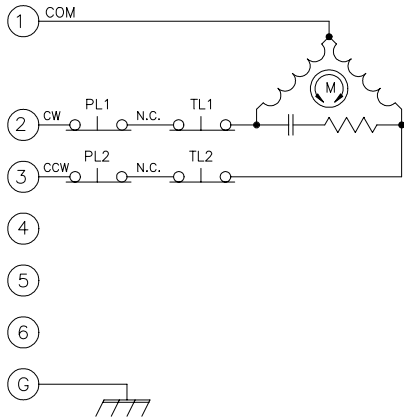

**SM-1740 (24 Vdc)**

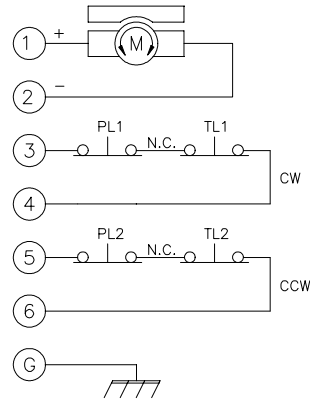

Actuator Action	AC Power Applied to Terminals		DC Power Applied to Terminals	
	1 & 2	1 & 3	1(+) & 2(-)	1(-) & 2(+)
Viewing Output Shaft	CCW	CW	CW	CCW

- Notes:**
1. The torque limit switches are factory set to trip if the rating of the actuator is exceeded.
  2. Shielded wire is required for position feedback signal wiring.

## SM-1715 SERIES ACTUATOR

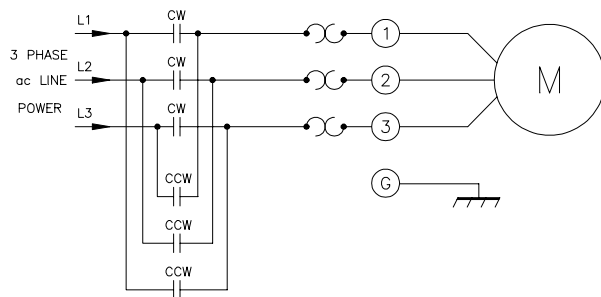

**Due to wide variations in terminal numbering of actuator products, actual wiring should follow the print supplied with the actuator.**

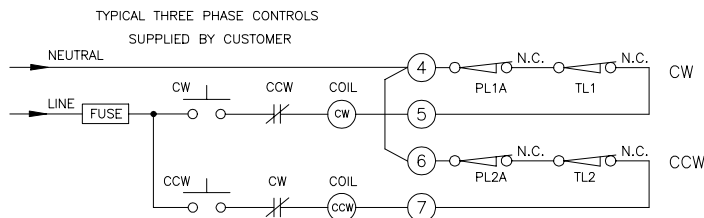

- Notes:**
1. Optional remote three phase reversing starter shown.
  2. Caution: Care must be taken in properly phasing position and torque limit switches with respect to clockwise and counterclockwise positioning.



## Typical Wiring Diagrams

### SM-1700 SERIES ACTUATORS WITH A BUILT-IN AD-8130 AMPLIFIER (120/240 Vac, Single Phase, 50-60 Hz)

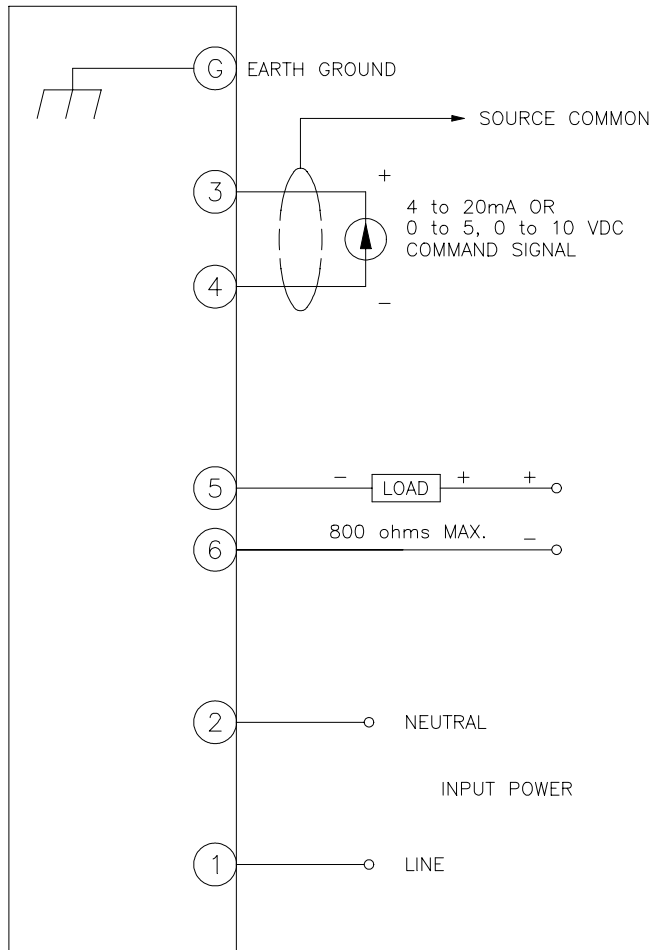

**Due to wide variations in terminal numbering of actuator products, actual wiring should follow the print supplied with the actuator.**

#### Notes:

1. All references to actuator output shaft rotation are as viewed facing the actuator output shaft.
2. An increasing command signal will result in CW rotation of the actuator output shaft.
3. The torque limit switches are factory set to trip if the torque exceeds the actuator rating.  
Do not adjust these trip points.
4. Shielded wire is required for command and position feedback signal wiring.
5. Command signal input:
  - 4 to 20 mA into a 200 ohm impedance
  - 0 to 5 or 0 to 10 Vdc into a 100,000 ohm impedance
6. The EC-10852 is for use with the AD-8130 servo amplifier with LVDT (voltage feedback). The EC-10852 is used as the HI and LO trim for the AD-8130. The AD-8130 is factory set for operation with the EC-10852. CAUTION: It is important not to adjust the HI and LO trim on the AD-8130, which are torque sealed at the factory. For specific Setup information and calibration, refer to the wiring diagram supplied with your unit. This option is not shown in the above diagram.

Refer to IM-0607 for complete information on the AD-8130 servo AMPLIFIER.

## ACTUATORS WITHOUT SERVO AMPLIFIERS

### A. POSITION LIMIT SWITCH ADJUSTMENT (Ref. Fig. 1)

#### NOTE:

The actuator is shipped in its mid-travel position.

1. Referring to your wiring diagram, apply motor power and drive the actuator in the CW output shaft direction (looking at the shaft), until PL1 trips and stops the actuator. This is the CW limit switch setting and starting point for final switch adjustment.
2. Move the controlled equipment to the same starting point and couple the actuator output shaft to the driven shaft.
3. Apply motor power to rotate the output shaft CCW about 5 degrees, allowing PL1 switch to reset.
4. Apply motor power to rotate the output shaft CW until PL1 trips, turning off the motor. If the driven device is not at the desired position:
  - a. Remove motor power.
  - b. Using an 1/8 inch, long shaft allen wrench, loosen Cam Screw #1 about 1/4 turn.
  - c. Rotate Cam #1 CCW to allow the actuator to run further in the CW direction or rotate the cam CW to turn the actuator off sooner. (Cam #1 will turn off the motor for CW output shaft rotation, when the switch roller lever moves to the high side of the cam with the cam rotating CW.)
  - d. Position the Cam as desired and while holding in place, tighten screw #1 with moderate force to adequately clamp the cam in place.

**DO NOT OVER TIGHTEN.**

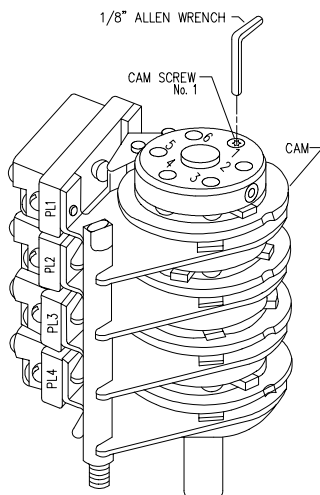

5. Apply motor power to drive the actuator to the desired CCW position or until PL2 trips and stops the motor. If the driven device is not at the desired position:
  - a. Remove motor power.
  - b. Loosen Cam Screw #2 about a turn.
  - c. Rotate Cam #2 CW to increase the actuator's total travel range or CCW to decrease the travel range.
  - d. Hold the cam in place and tighten screw #2.
6. Electrically operate the actuator to its CW limit and back to the CCW limit to check switch settings. Readjust Cam #1 or #2 as needed.
7. Switches 3 through 6 (optional) are adjusted by loosening their respective cam screws and rotating the cam. They may be set anywhere within the range of PL1 or PL2.
8. If the unit is equipped with a feedback device and switches PL1 or PL2 were readjusted, proceed with the proper feedback alignment prior to any further adjustments or operation of the actuator.

### B. 1000 OHM POTENTIOMETER ADJUSTMENT

1. Run the actuator to the center of travel. Loosen the three panhead screws, securing the potentiometer body, and rotate it to its center of travel (500 ohm) position. An ohmmeter will be required for this adjustment. Tighten the three screws.
2. Run the actuator to the zero or minimum travel limit. With the actuator running, monitor the potentiometer with an ohmmeter to ensure the potentiometer deadband is not crossed.
3. If your system requires a low resistance starting point, loosen the three screws and rotate the potentiometer body for the required starting resistance. This is usually 20 to 50 ohms (measured from the potentiometer wiper arm to the zero end of the potentiometer).

### C. 4 to 20mA TRANSMITTER OPTION ADJUSTMENT

The ST-4130 (1000 ohm-input, 4 to 20 mA output) two wire transmitter modulates the current on a direct current supply proportional to the input resistance. It is powered by a 12.0 to 36.0 Vdc regulated power supply line which is modulated from 4 to 20 mA proportional to the resistance of the input.

## Start Up

For the unit to function optimally, the 4mA end of the feedback potentiometer must be preset to 50 ohms.

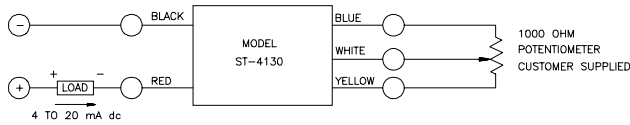

1. Position the actuator to the desired 4mA setting.
2. With potentiometer resistance at 50 ohms, adjust ELEVATION for 4.0mA output.
3. Position the actuator to the desired 20mA setting.
4. Adjust RANGE for 20mA output.
5. Repeat steps 1 through 4 until desired accuracy is achieved.
6. To reverse the 4 and 20mA output, interchange the BLUE and YELLOW wires and return to step 1.

### D. ACTUATOR WITH INTEGRAL AD-8130 SERVO AMPLIFIERS

Switch and feedback potentiometer alignment is accomplished in the same manner as actuator without amplifiers, except motor power is supplied from the amplifier. Varying the command signal input to the amplifier will allow reversal of the rotation of the actuator output shaft to run to the minimum/maximum switch settings. If the actuator does not run to the limit switch, but stops short, the amplifier has nulled and adjustments of span, elevation, loss of signal, or feedback potentiometer may be required. Refer to IM-0607 for information on the AD-8130 amplifier.

The EC-10852 is for use with the AD-8130 servo amplifier with LVDT (voltage feedback). The EC-10852 is used as the HI and LO trim for the AD-8130. The AD-8130 is factory set for operation with the EC-10852. **CAUTION: It is important not to adjust the HI and LO trim on the AD-8130, which are torque sealed at the factory.** For specific Setup information and calibration, refer to the wiring diagram supplied with your unit.

### E. CHARACTERIZED CAM ADJUSTMENT (OPTION)

The characterized feedback assembly is an option which directly replaces the standard linear feedback potentiometer.

Prior to adjusting the cam, the end of travel limit switches must be set and the proper cam installed for your particular system requirements on the characterized cam shaft. Four different cams are supplied with each characterized assembly. The cams are printed on both sides and may be flipped over to reverse the characterization action in relation to the output shaft rotation.

The cams are each printed with a letter "O", "F", or "B" which indicate the cam type. Three of the cams are shaped to correspond to  $X=2$ , 1, and 0.5 respectively in the equation:

$$\% \text{ amplifier input} = (\% \text{ shaft rotation})x$$

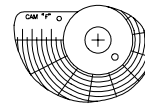

CAM F  
SQUARE (X = 2)

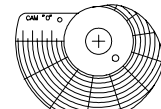

CAM O  
LINEAR (X = 1)

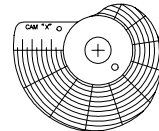

CAM X  
SQUARE ROOT (X = 0.5)

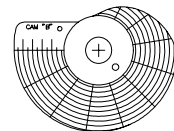

CAM B  
MAXIMUM (CUT AS NEEDED)

The fourth cam is used for any value of  $x$  between 0.5 and 2 and must be cut by the user. For details on cutting this cam, see "To Shape Feedback Cam".

- a. Run the actuator to the zero or minimum position limit. While running, observe the direction of character cam rotation.
- b. Is the cam rotating in the direction of 100-0 for your system requirement? If not, remove the thumb screw and flip the cam over. Tighten the screw.
- c. Have you selected the proper cam for the system requirement? If not, remove the thumb screw and change the cam, installing the cam the same as in (b) above. (Green or Black side up.)
- d. Loosen three screws and remove the cam assembly.
- e. Rotate the cam until the zero on the cam is in line with the center line of the potentiometer or LVDT shaft.
- f. Potentiometers need no further adjustment.
- g. LVDT contactless feedback may require fine zeroing.
  - i. Apply power to the LVDT and monitor the output with a volt meter.
  - ii. Loosen the two body clamp screws and slide the body of the LVDT to obtain zero output.
  - iii. Tighten the body clamp screws.
  - iv. If a finer adjustment is desired, loosen the nut on the LVDT shaft and turn the shaft slightly one way or the other and tighten the nut.

### TO SHAPE FEEDBACK CAM

With characterized feedback, one of the four cams supplied (cam B), is partially shaped. For installation, it must be cut to its final shape by the user. This cam is used if none of the other three cams produces the desired input-output relationship where:

$$\% \text{ amplifier input} = (\% \text{ shaft position})X$$

Two typical conditions where the user might want to use the fourth cam are:

1. In equation above, if the value of  $X$  is not equal to 0.5 or 2.

# Start Up

2. In equation, if the value of X is equal to 0.5 or 2, and if upper shaft position is not equal to 100% (90°), and/or lower shaft position is not equal to 5% (0°).

To lay out the cam shape for the desired input-output relationship, it is necessary to determine outputs (rise in cam), for various inputs (amount of cam rotation). The rise in the cam corresponds to % of maximum output range and the amount of cam rotation corresponds to % input signal to amplifier.

1. Lay out on graph paper, axes and maximum and minimum slopes as shown in figure 2. (Maximum slope is 25 units rise per 10% shaft rotation; minimum slope is 5 units per 10% rotation.)
2. If either upper or lower shaft position is not at 0 or 100° (0° or 90°) respectively, lay out additional x-axis scale as shown in figure 3 on page 13. Use both sets of values when plotting cam shape in step 3.
3. Calculate outputs (rise in cam) for 5% or 10% increments in input for entire input scan (actual cam rotation). NOTE: only output values that fall within maximum and minimum slope lines can be used.
4. Plot these values on cam. Scribe smooth line between points and grind cam to this shape.

Refer to example for typical cam calculations and layout.

## TYPICAL FEEDBACK CAM CALCULATIONS

EXAMPLE: Assume X in (input/output equation) = 0.5, and that upper and lower shaft positions are at 100% and 20% (90° and 18°), same as center illustration of Figure 3.

Figure 1

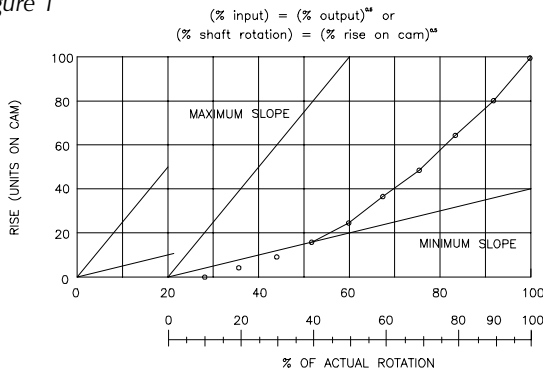

Input % of actual rotation	Output	
	location on cam	% rise on cam
0	20%	0
10	28	1*
20	36	4*
30	44	9*
40	52	16
50	60	25
60	68	36
70	76	49
80	84	64
90	92	81
100	100	100

Note: These values fall outside of minimum slope on graph.

Figure 2

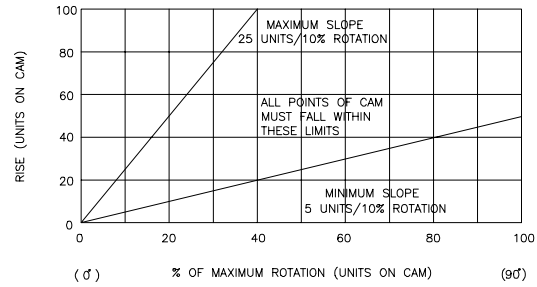
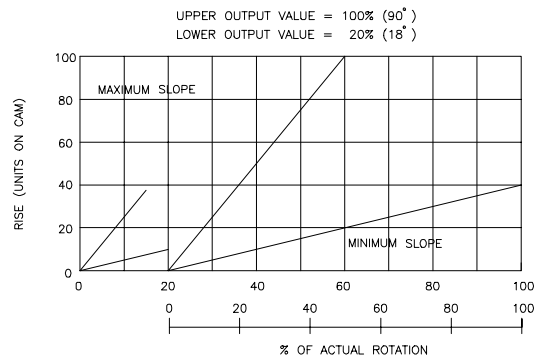
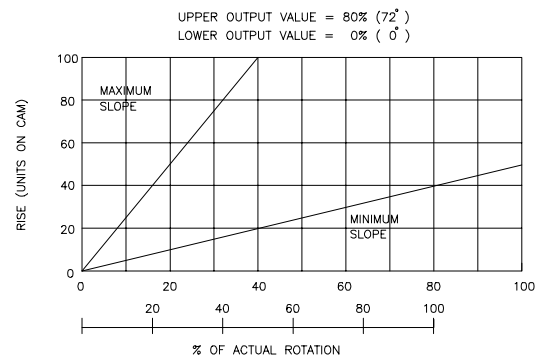
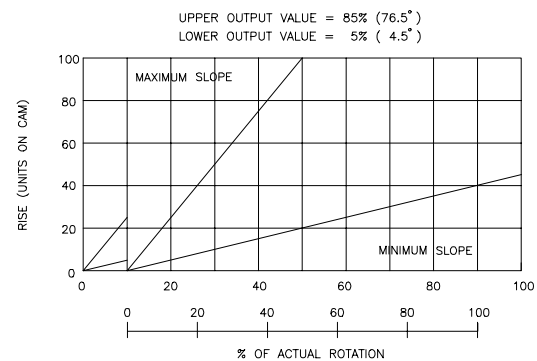

Figure 3

Illustrations below show an 80% (72°) shaft rotation span.



IF LOWER SHAFT POSITION IS NOT EQUAL TO 0% (0°) REDRAW SLOPE LIMITS TO GO THROUGH ACTUAL STARTING ROTATION POINT, AS SHOWN ABOVE.



IF LOWER SHAFT POSITION IS NOT EQUAL TO 0% (0°) REDRAW SLOPE LIMITS TO GO THROUGH ACTUAL STARTING ROTATION POINT, AS SHOWN ABOVE.

## Troubleshooting Guide

TROUBLE	POSSIBLE CAUSE	REMEDY
Motor does not operate	a. No power to actuator	a. Check source, fuses, wiring
	b. Motor overheated and internal thermal switch tripped (single phase AC motors only)	b. Let motor cool and determine why overheating occurred (such as, excessive duty cycle or ambient temperature)
	c. Motor burned out	c. Replace motor and determine cause of failure
	d. Motor drag brake improperly adjusted	d. Adjust as detailed on page 20
	e. Motor drag brake defective	e. Replace drag brake
	f. Both end of travel switches open or one open and one defective	f. Adjust switch settings or replace defective switch
	g. Actuator output shaft stalled	g. Check drive load for mechanical jam and correct cause
	h. Defective motor run capacitor	h. Replace capacitor (AC models)
	i. Load exceeds actuator torque rating	i. Reduce load or replace actuator with one with appropriate torque rating
	j. Power applied to CW & CCW rotation at same time	j. Correct power input problem
	k. Amplifier defective	k. Replace amplifier
	l. Amplifier is in Loss of Signal	l. Check command signal to verify signal greater than 3.8 mA is present
	m. Amplifier deadband is too wide	m. Reduce deadband setting
Motor hums but does not run	a. Power applied to CW & CCW rotation at the same time	a. Correct power input problem
	b. Damaged power gearing	b. Repair gearing
	c. Defective motor run capacitor	c. Replace capacitor
	d. Motor drag brake	d. Adjust or replace as required
Motor runs, output shaft does not rotate	a. Defective power gearing	a. Repair gearing
Motor does not shut off at limit switch	a. Switch wired wrong or is defective	a. Correct wiring or replace switch
	b. Motor phased incorrectly	b. Correct wiring
Actuator backdrives when power is removed	a. Motor drag brake improperly adjusted	a. Adjust as detailed on page 20
	b. Motor drag brake defective	b. Replace drag brake
Handcrank does not move output shaft	a. Power still on	a. Remove power
	b. Load is jammed and motor drag brake slips	b. Remove jammed load
	c. Drag brake missing or improperly adjusted.	c. Replace drag brake

## Troubleshooting Guide

Motor runs, but only one way	a. Power not applied for other direction	a. Correct power problem
	b. Power always applied to one direction and electrically stalls when applied for opposite direction	b. Correct power problem
	c. Open limit switch for other direction	c. Adjust or replace limit switch as required
	d. Actuator is torqued out	d. Determine obstruction and correct
	e. Motor has an open winding	e. Replace motor
	f. Motor and feedback potentiometer are out of phase	f. Reverse potentiometer end leads
	g. Amplifier is defective	g. Replace amplifier
Poor response to command signal changes	a. Amplifier deadband is too wide	a. Reduce deadband setting
	b. Amplifier is defective	b. Replace amplifier
	c. Excessive noise on command signal	c. Reduce noise. Also ensure that command signal wiring is shielded with shield grounded at source common only.
	d. Defective feedback potentiometer	d. Replace potentiometer
Actuator oscillates at setpoint	a. Amplifier deadband is too narrow	a. Increase deadband setting
	b. Amplifier is defective	b. Replace amplifier
	c. Excessive noise on command signal	c. Reduce noise. Also ensure that command signal wiring is shielded with shield grounded at source common only.
Pot feedback signal not always present during actuator rotation	a. Pot not aligned with end of travel extremes and is being driven through dead region	a. Align pot to range of actuator
	b. Pot signal is erratic or nonexistent	b. Replace pot
Pot signal does not change as actuator operates	a. Defective pot	a. Replace pot
	b. Feedback gear not turning pot shaft	b. Check gearing engagement and set screw in gear hub
Pot signal is reversed for output shaft rotation	a. Pot is wired wrong	a. Reverse wiring from ends of pot at actuator terminal block
Output shaft rotates wrong direction for CW and CCW input power	a. Wiring to actuator incorrect	a. Correct field wiring
	b. Wiring from motor to terminals or switches is reversed	b. Correct internal actuator wiring
4-20 mA customer feedback missing or non-linear	a. External wiring error	a. Refer to IM-0607
	b. Power supply fault	b. Refer to IM-0607
	c. Shunt resistance too light	c. Refer to IM-0607



# Parts Identification

## GEAR LOCATION

### Front View

Letters in balloons refer to gear assembly drawing on page 15.

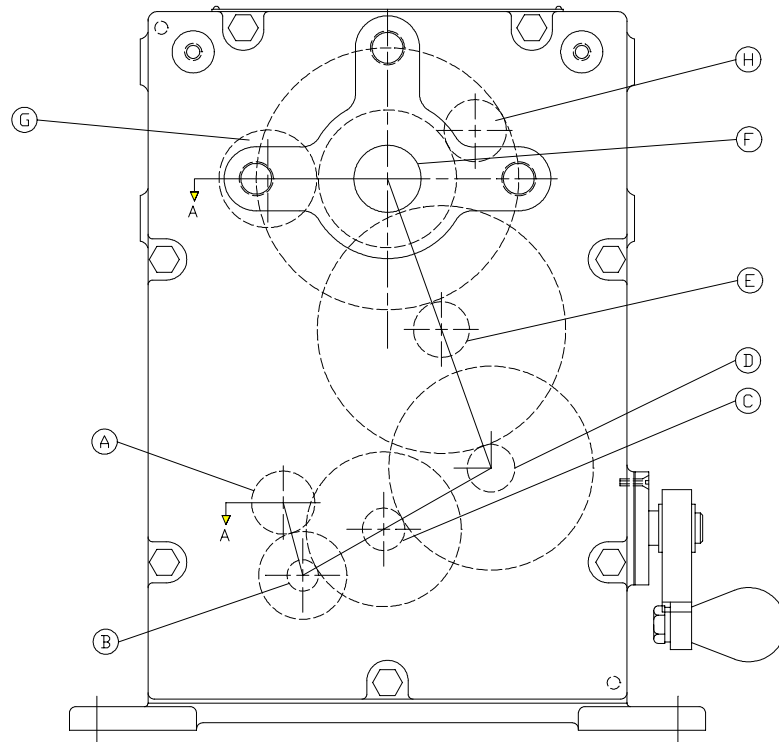

### Side View

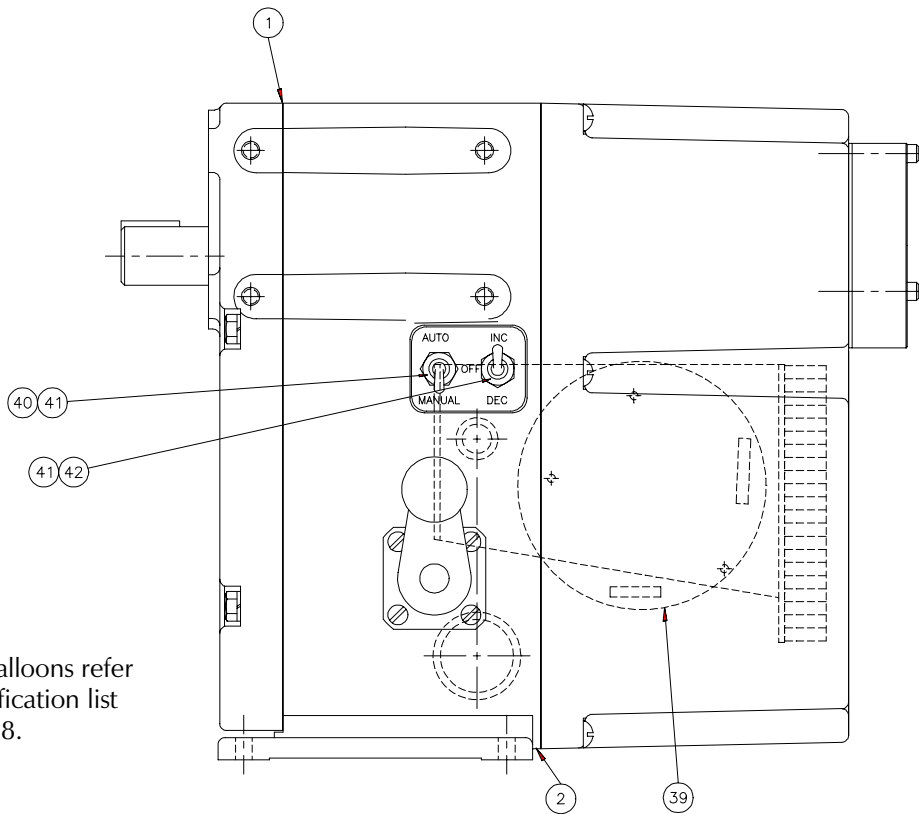

Numbers in balloons refer to parts identification list on pages 17-18.

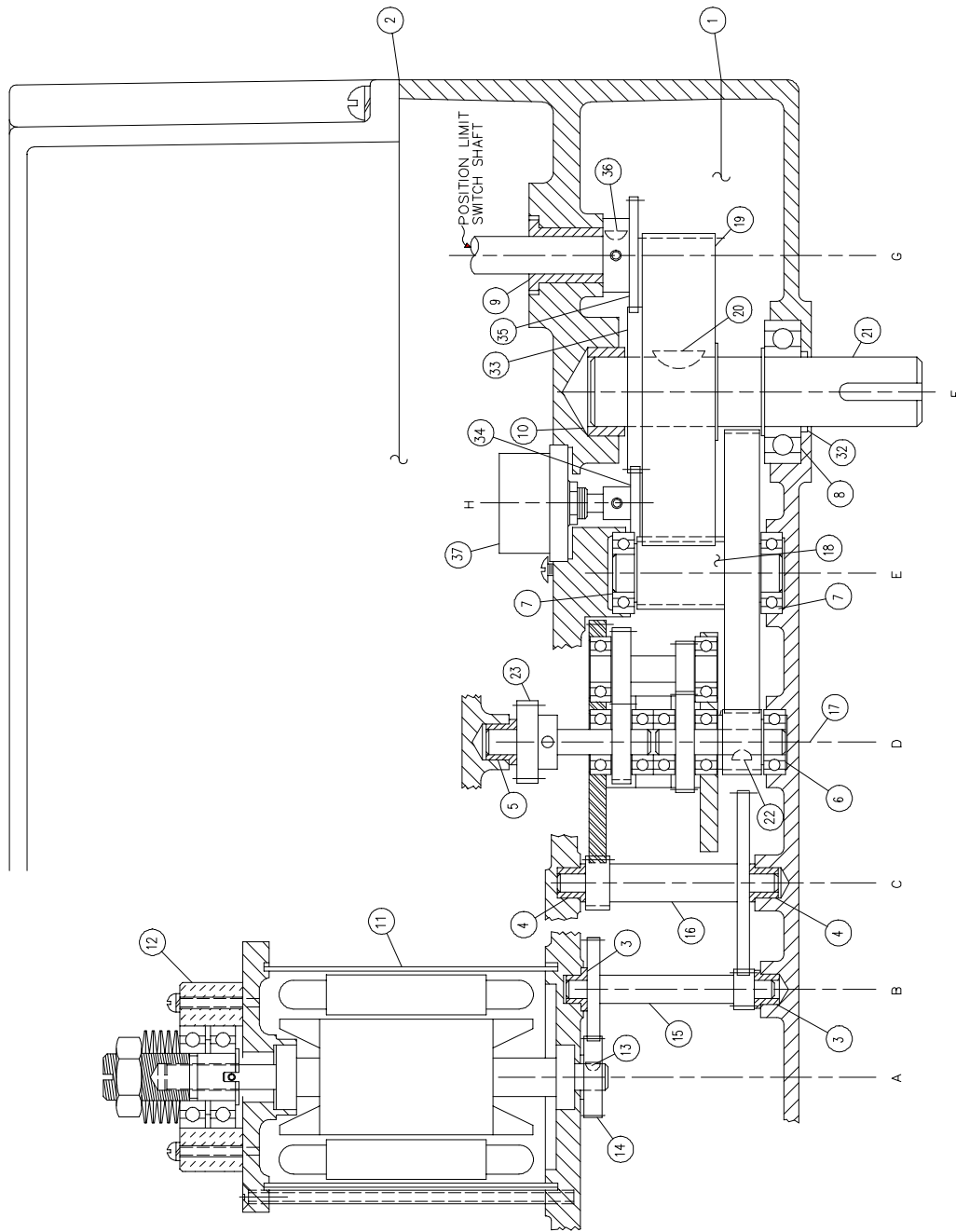

**GEAR ASSEMBLY**

Numbers in balloons refer to parts identification list on pages 17-18.

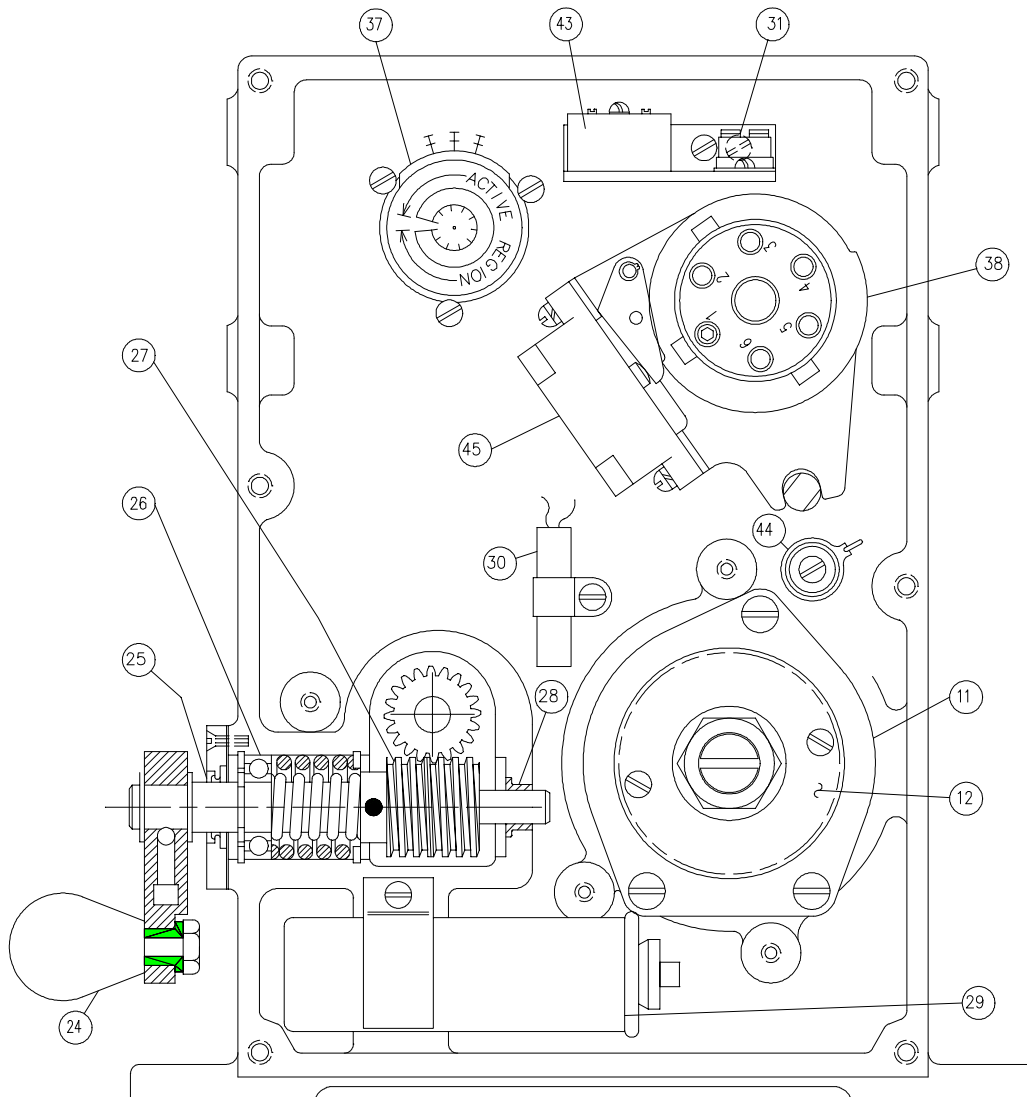

## LIMIT SWITCH COMPARTMENT

Numbers in balloons refer to parts identification list on pages 17-18.

# Spare Parts List

## Recommended Spare Parts Indicated in Bold

ID	DESCRIPTION	PART NUMBER	QTY
1	Gasket, Gear Cover	13C-016024-001	1
2	<b>Gasket, Rear Cover</b>	<b>13C-015754-001</b>	1
3	Bushing (2nd Stage)	18B-SP1988-067	2
4	Bushing (3rd Stage)	18B-SP1988-007	2
5	Bushing (4th Stage)	18B-SP1988-068	1
6	Bearing (4th Stage)	17B-003813-007	1
	Bearing (4th Stage)*	17B-003813-077	1
7	Bearing (5th Stage)	17B-003813-004	2
	Bearing (5th Stage)*	17B-003813-083	2
8	Bearing (Output Shaft)	17B-003813-031	1
9	Bushing (Sw itch Shaft)	18B-SP1988-057	1
10	Bushing (Output Shaft)	18B-003814-029	1
	Bearing (Output Shaft)*	17B-003813-084	1
11	<b>Motor</b> (See Motor Selection on p. 20)		1
12	<b>Drag Brake Ass'y (ac)</b> (except 31/1800)	<b>68C-035339-001</b>	1
	<b>Drag Brake Ass'y (ac)</b> (31/1800 only)	<b>68C-038298-001</b>	1
	<b>Drag Brake Ass'y (dc)</b>	<b>68C-035339-002</b>	1
13	Woodruff Key #202	58B-016181-001	1
	Woodruff Key #404	58B-016181-009	1
14	<b>Pinion Gear</b> (See Gear Chart on page 20)		1
15	<b>Gear Ass'y</b> (2nd Stage) (See Gear Chart on page 20)		1
16	<b>Gear Ass'y</b> (3rd Stage)	<b>65A-016036-001</b>	1
17	<b>Planetary Gear Ass'y</b> (4th Stage)	<b>65C-016048-001</b>	1
	<b>Planetary Gear Ass'y</b> 4th Stage	<b>65B-036953-001</b>	1
18	<b>Gear Ass'y</b> (5th Stage)	<b>65A-016027-001</b>	1
	<b>Gear Ass'y</b> (5th Stage)*	<b>65A-016027-002</b>	1
19	<b>Output Shaft Gear</b>	<b>16B-016030-001</b>	1
	<b>Output Shaft Gear *</b>	<b>16B-036930-001</b>	1
20	Woodruff Key #606	58B-016181-016	1
	Key 0.25"square x 2' long *	61B-010954-464	1
21	Output Shaft - Splined	62B-016028-001	1
	Output Shaft - Keyed	62B-016029-001	1
	Output Shaft - Splined *	62B-036936-001	1
	Output Shaft - Keyed *	62B-036935-001	1
22	Woodruff Key #204	58B-016181-007	1
23	Gear, Helical	16A-015674-001	1
	Gear, Helical*	16A-015674-002	1
24	Knob	74A-016182-001	1
25	Lip Seal, Handcrank	19B-003815-017	1
26	Bearing, Handcrank	17B-003813-011	1

27	Worm Gear	16A-015673-001	1
28	Bushing	18B-SP1988-066	1
29	Capacitor 5 MFD (1710)	24B-029812-005	1
	Capacitor 10 MFD (1720)	24B-029812-008	1
	Capacitor 10 MFD (1730)	24B-029812-007	1
	Capacitor 3 MFD (1750)(1790)	24B-029812-004	1
	Capacitor 2 MFD (1770)	24B-029812-003	1
30	Heater 120V, 30W	74A-016946-001	1
	Heater 240V, 75W	74A-016946-002	1
31	Thermal Sw itch	74A-023565-001	1
32	"O" Ring	74B-012708-022	1
33	Gear, Feedback	16B-003804-100	1
34	Gear, Pot	16B-003803-096	1
35	Gear, Limit Sw itch	61A-025809-001	1
36	Woodruff Key #404	58B-016181-009	1
37	<b>Potentiometer, 1K ohm</b>	<b>34B-033104-001</b>	1
38	2 SPDT (AC units)	68D-021669-001	1
	4 SPDT (AC units)	68D-021669-002	1
	6 SPDT (AC units)	68D-021669-003	1
	2 SPDT (DC units)	68D-021669-004	1
	4 SPDT (DC units)	68D-021669-005	1
	6 SPDT (DC units)	68D-021669-006	1
	2 DPDT	68D-021669-007	1
	4 DPDT	68D-021669-008	1
	6 DPDT	68D-021669-009	1
	39	<b>AD-8130 Servo Amplifier</b>	<b>68C-035658-001</b>
AD-8130/EC-10835 w/o 24 Vdc power supply**		70C-035950-001	1
AD-8130/EC-10835 w ith 24 Vdc power supply**		70C-035950-002	1
40	Selector Sw itch	46B-004053-319	1
41	Rubber Boot	46B-004053-320	2
42	Selector Sw itch	46B-004053-313	1
43	<b>4-20 mA Transmitter</b>	<b>70A-019948-001</b>	1
44	Resistor 10 ohm, 25W	33B-003852-205	1
45	<b>SPDT (AC unit)</b>	<b>46A-010017-001</b>	2
	<b>SPDT (DC unit)</b>	<b>46A-010017-003</b>	2
	<b>DPDT</b>	<b>46A-010017-002</b>	2
46	Characterized Cam Set	68A-017793-005	2
47	Potentiometer 1K ohm Linear (for characterized cam set)	68C-015435-001	1
	LVDT (for characterized cam set)	68C-019632-001	1
48	Torque Limit Sw itch (not show n)	46B-004053-416	2

## Motor, Motor Pinion Gear & 2nd Stage Gear Assy. Selection

Model	Shift Time (sec.)	Motor Part # (Item 11)	Motor Pinion Gear Part # (Item 14)	2nd Stage Gear Assy. Part # (Item 15)
SM-1710	12	61B-026406-004	16B-015633-001	65B-016034-001
	24	61B-026406-004	16B-015633-003	65B-016034-003
	48	61B-026407-001	16B-003806-015	65B-016034-005
SM-1715	12	23C-038332-001	16B-015633-001	65B-016034-001
	24	23C-038332-001	16B-015633-003	65B-016034-003
	48	23C-038333-001	16B-003806-015	65B-016034-005
SM-1720 SM-1790	31	61B-026406-003	16B-015633-004	65B-016034-008
	60	61B-026407-002	16B-017896-001	65B-016034-007
SM-1730	12	61B-026406-003	16B-015633-001	65B-016034-001
	24	61B-026406-003	16B-105633-003	65B-016034-003
	48	61B-026407-002	16B-015633-015	65B-016034-005
SM-1740	16	61B-026404-001	16B-015633-003	65B-016034-003
	31	61B-026405-001	16B-003806-015	65B-016034-005
	40	61B-026405-001	16B-017896-001	65B-016034-006
SM-1750	12	61B-026406-001	16B-015633-001	65B-016034-001
	24	61B-026406-001	16B-015633-003	65B-016034-003
	48	61B-026407-003	16B-003806-015	65B-016034-005
SM-1770	12	61B-026406-002	16B-015633-001	65B-016034-001
	24	61B-026406-002	16B-015633-003	65B-016034-003
	48	61B-026407-004	16B-003806-015	65B-016034-005

**Note:** Models with 12, 24 or 48 seconds shift time were previously rated 17, 34 and 67 seconds respectively.

### LUBRICATION

Under normal service conditions the motor, gearing, bearings, and parts are all pre-lubricated and should not require periodic maintenance. If for any reason the unit is disassembled in the field, all oilite bushings should be resaturated with an SAE-10, non-detergent oil and all gearing heavily coated with Amoco Rykon Premium Grease #2 or equivalent grease. Care should be taken to ensure that no foreign material is allowed to become combined with the grease in the gear train, which will cause premature failure. Keep gearbox clean and dry.

### DRAG BRAKE ADJUSTMENT

The drag brake serves two functions: a) to prevent actuator from backdriving at maximum rated torque; and b) to allow the motor shaft to slip when handcranking and the output shaft load is in excess of rated torque.

The drag brake was factory set and should not need readjustment. If it does need adjustment:

1. Apply an overhung load, equal to the maximum torque rating to the output shaft.
2. Loosen drag brake jam nut until the motor shaft starts to backdrive.
3. Tighten the drag brake jam nut just enough to prevent backdriving.
4. While handcranking against the load, increase the load until motor backdriving occurs.

### TORQUE LIMIT SWITCH ALIGNMENT

The torque limit switches are factory set and field adjustment is not advised unless proper test equipment is available. If adjustment must be done, use the following procedure:

1. Load the output shaft with a known load which matches the torque rating of the actuator in an opposing direction for the switch being adjusted.
2. Apply power to the motor and run the actuator to drive the opposing load.
3. Increase the load by 5% to 10% and adjust the set screw (140C) to trip the torque switch.
4. Remove the 5% to 10% increase of load and the switch should reset.
5. Load the actuator in the opposite direction and set the other switch in the same manner.

**NOTE: When looking at the torque limit switch assembly as it is mounted in the actuator, the switch on the top of the assembly controls the CW torque and the switch on the bottom controls the CCW torque. The torque should be set near equal for both directions.**

**When the actuator is driven into a torque condition in the CW direction (looking at the output shaft), the handcrank handle will move slightly outward. For CCW direction the handle will pull slightly inward.**



## Maintenance

### MOTOR REPLACEMENT

1. Disconnect all power to the actuator.
2. Remove screws, washers and rear cover.
3. Disconnect actuator output shaft from driven device and remove actuator from mount.
4. Remove bolts, washers, and front gear case cover. Note location of all gearing.
5. Remove motor pinion.
6. Remove brake assembly from top of motor.
7. Disconnect motor wires - note colors.
8. Remove motor.
9. Reverse the procedure to install new motor. (Clean and regrease all gearing, check bushings and bearings, lubricate bushings with SAE-10, non-detergent oil.)
10. Reinstall the actuator.

### POWER GEARING REPLACEMENT

1. Perform steps 1,3 & 4 of Motor Replacement.
2. Remove defective gear(s) and replace with new.
3. Ensure all gearing and oilite bushings are properly lubricated as detailed above.
4. Install front cover and Reinstall actuator.

### POSITION LIMIT SWITCH REPLACEMENT

1. Disconnect all power to the actuator.
2. Remove rear cover.
3. Remove two screws and washers from appropriate switch on assembly.
4. Install new switch and transfer wires from old switch one at a time.
5. No realignment should be necessary.

### FEEDBACK POTENTIOMETER REPLACEMENT

#### A. One Turn Linear Potentiometer

1. Disconnect all power to the actuator.
2. Remove screws, washers, and rear cover.
3. Remove three screws holding potentiometer and disc to housing.
4. Pull potentiometer and disc out of housing.
5. Measure location of gear from mounting disc to farthest face of gear and note measurement.
6. Loosen set screws and remove gear.
7. Remove nut and washer holding potentiometer to disc.
8. Cut shaft of new potentiometer to same length as old.
9. Mount new potentiometer on disc, tighten potentiometer nut, install gear to measured dimension from step 5.
10. Install assembly in housing and tighten screws.
11. Using a 25 watt solder iron, remove wires from old potentiometer one at a time and solder to corresponding terminals on new potentiometer.
12. Align potentiometer and install cover.

#### B. Characterized Potentiometer

1. Disconnect power and remove rear cover.
2. Remove three screws and pull potentiometer off of pins.
3. Install new potentiometer and tighten screws.
4. Using a 25 watt solder iron, remove wires from old potentiometer one at a time and solder to corresponding terminals on new potentiometer.  
**CAUTION - DO NOT USE EXCESSIVE HEAT WHEN SOLDERING.**
5. Align potentiometer and install cover.

#### C. LVDT Assembly Replacement

1. Same as Characterized Potentiometer replacement above.
2. Align LVDT body for zero output (see alignment procedure, characterized cam adjustment on page 12, step G).

# Linkage Options

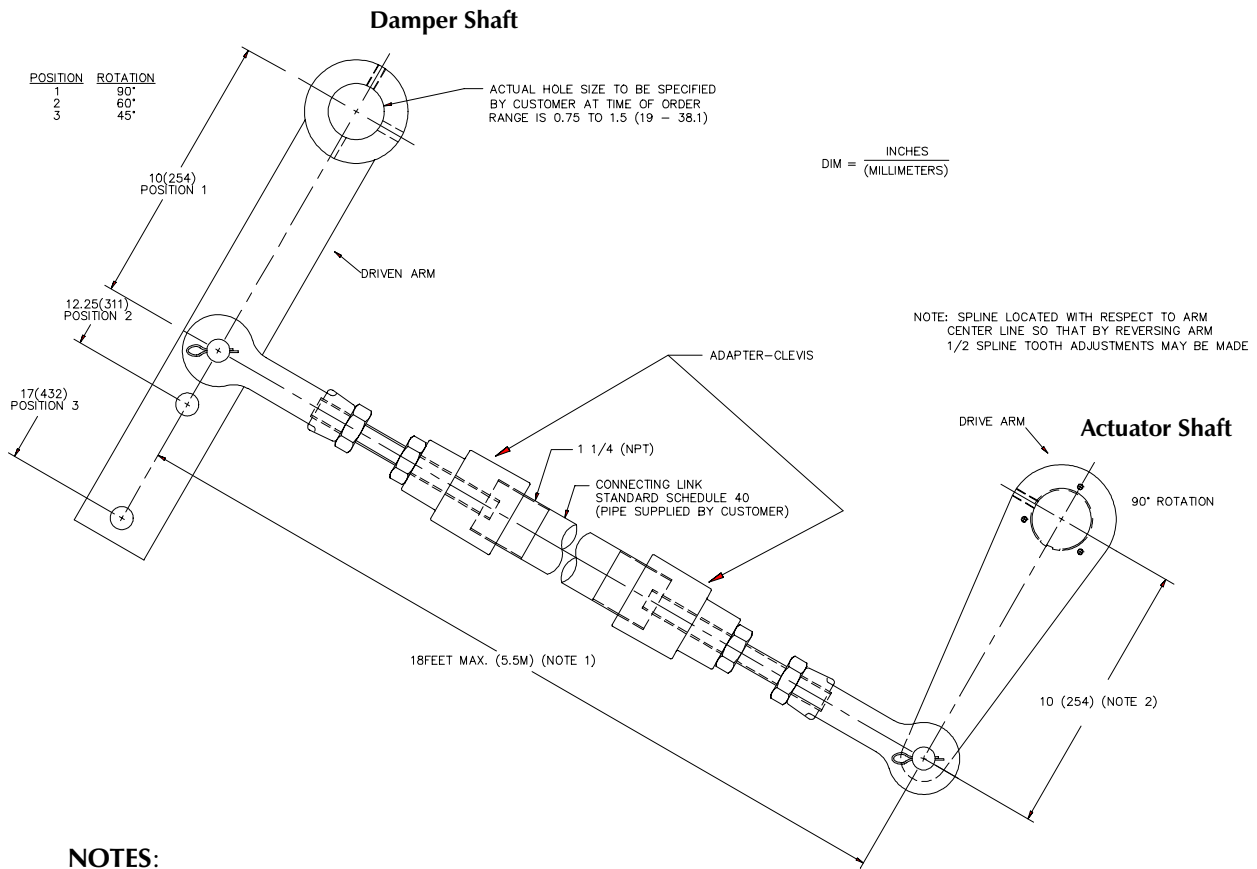

## NOTES:

1. Maximum total link length is specified to prevent buckling under compressive load.
2. Adjustable drive arms are also available to allow length to vary from 6 to 10 inches (152 to 254 mm). In this case, the adapter-clevis has rod ball ends with lubrication fittings.
3. Weight of all linkage components (including customer supplied schedule 40 pipe) must be taken into consideration when calculating total actuator torque requirements.

# Major Dimensions

INCHES  
(MILLIMETERS)

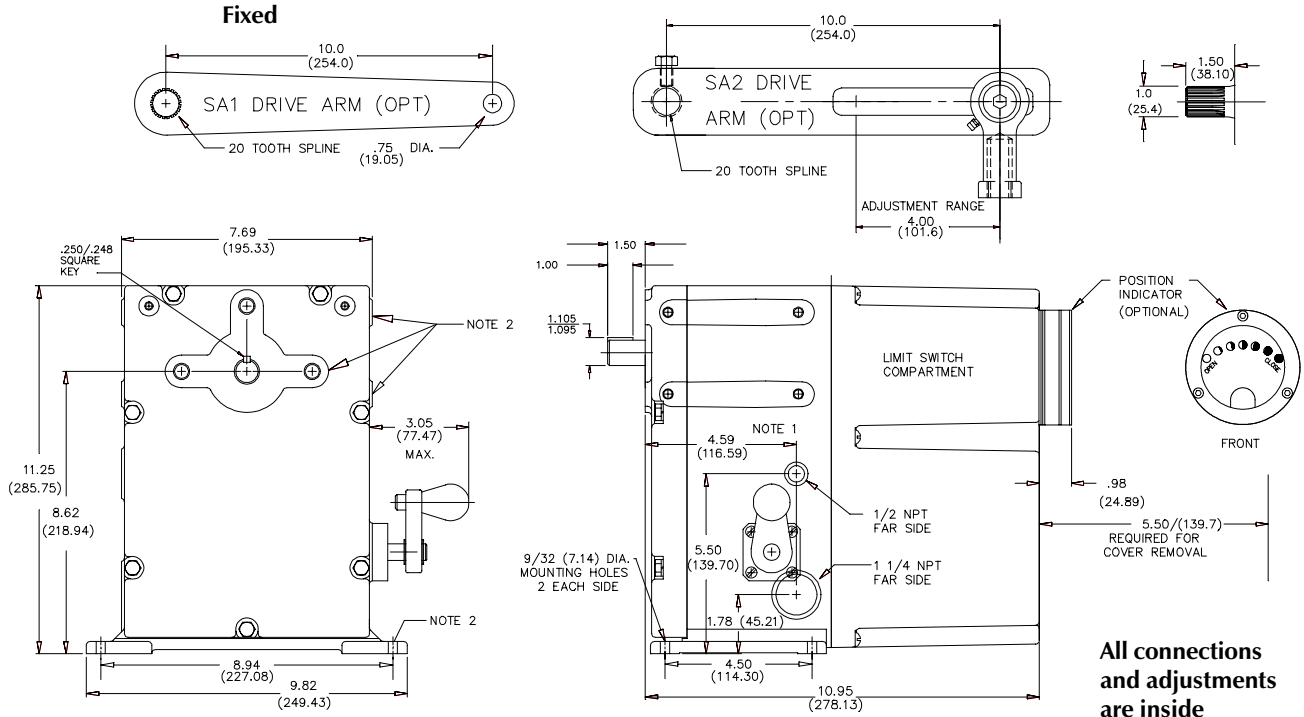

## NOTES:

1. The optional local toggle switches are located on this surface.
2. The SM-1700 series actuators can be foot, face or side mounted.
3. Overall depth is approximately 13 inches (330 mm) on the SM-1715 three phase model.
4. The output shaft is available in a one inch (25.4 mm) diameter with 1/4 inch (6.35 mm) square keyway, or with the optional spline, as shown in upper right hand corner.

# rotork®

Keeping the World Flowing



[www.rotork.com](http://www.rotork.com)

A full listing of our worldwide sales and service network is available on our website.

*UK*

Rotork plc

*tel* +44 (0)1225 733200

*fax* +44 (0)1225 333467

*email* [mail@rotork.com](mailto:mail@rotork.com)

*USA*

Rotork Controls

*tel* +1 (414) 461 9200

*fax* +1 (414) 461 1024

*email* [info@rotork.com](mailto:info@rotork.com)

Rotork is a corporate member of the Institute of Asset Management



PUB050-002-00  
Issue 04/17

As part of a process of on-going product development, Rotork reserves the right to amend and change specifications without prior notice. Published data may be subject to change. For the very latest version release, visit our website at [www.rotork.com](http://www.rotork.com)

The name Rotork is a registered trademark. Rotork recognises all registered trademarks. Published and produced in the UK by Rotork Controls Limited. POWJB0417